

Class 800 Forged Stainless Steel Swing Check Valve

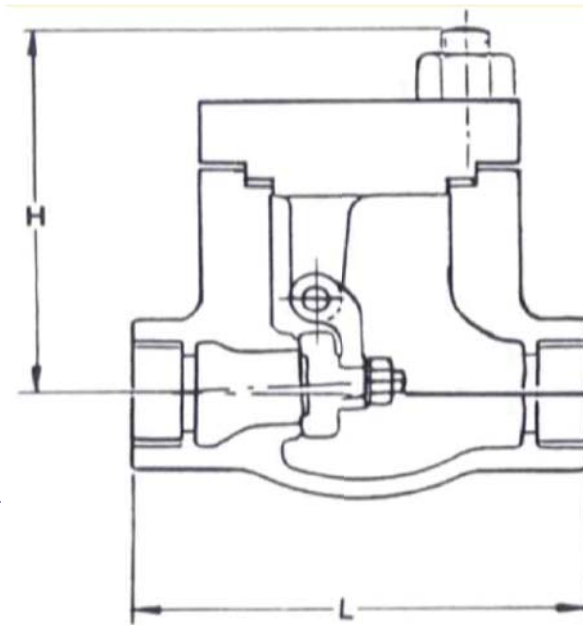

Fig. SC-800R

Parts	Material	ASTM
Body	Forged Steel	A182-F316L
Seat Ring	Stainless Steel	A276-316
Disc	Stainless Steel	A276-316
Hinge	Stainless Steel	A351-CF8M
Name Plate	Stainless Steel	
Cover Bolt	Stainless Steel	A193-B8
Cover	Forged Steel	A182-F316L
Gasket	304 Hoop-Asbestos	
Support	Stainless Steel	A276-316
Support Pin	Stainless Steel	A276-316
Ret. Washer	Stainless Steel	A276-316

SEAT RING: STELLITE HARD FACING

Valve Size	in	1/2"	3/4"	1"	1 1/4"	1 1/2"	2"
	mm	15	20	25	32	40	50
L Face to Face	in	3"	3 3/8"	4"	6"	6"	6 3/4"
	mm	76	86	102	152	152	172
H Height	in	1 7/8"	2 1/8"	2 1/2"	3 3/16"	3 3/16"	4 1/8"
	mm	48	54	63	81	81	105

DIMENSIONS (inch : mm)